

Improvement in Pre-Regulation for Power Factor Using CUK Converter

Venkata Siva Prasad¹, Deepak Kumar Jena²

¹ Department of Electronics & Communication Engineering, Gandhi Engineering College, Odisha, India

² Department of Electronics & Communication Engineering, Gandhi Institute For Technology, Odisha, India

ABSTRACT-: Cuk converters, operating in Discontinuous Capacitor Voltage Mode can achieve unity power factor when used as rectifiers with no need of duty-cycle modulation. This operating mode causes high voltage stresses across the semiconductors, calling for high-voltage switches like IGBT's. However, zero-voltage turn-off is achieved, resulting in limited power loss even at high frequency. Both current- and voltage-fed approaches as well as constant- and variable-frequency control are analyzed in the paper. Simulation and experimental results are Explained, which demonstrate actual converter performance. Most of the power factor regulator topologies in continuous conduction mode result in bulky magnetic, and in discontinuous conduction mode result in high harmonic content. To solve these problems a Cuk topology is presented in discontinuous conduction mode with coupled inductors for power factor regulation, the unique feature exhibited by the converter that makes the converter better than the other converter in operation for power factor regulation. Inductive coupling is used to transfer the ripple from the input to the output side thereby reducing the switching harmonics in the line current. Experimental results obtained on a some Watt prototype are alsopresented.

Keywords-: CUK, Semiconductors, Ripple, Power- Factor

I. INTRODUCTION

Switch Mode Power Supply topologies follow a set of rules. A very large number of converters have been proposed, which however can be seen to be minor variations of a group of basic DC-DC converters – built on a set of rules. Many consider the basic group to consist of the three: BUCK, BOOST and BUCK-BOOST converters[1]. The CUK, essentially a BOOST-BUCK converter, may not be considered as basic converter along with its variations. In DC-DC voltage regulators, it is important to supply a constant output voltage, regardless of disturbances on the input voltage. The goal of this paper is to describe a feedback compensation technique for the Cuk converter (Fig 1) to limit the voltage deviation in response to a voltage step on theinput.

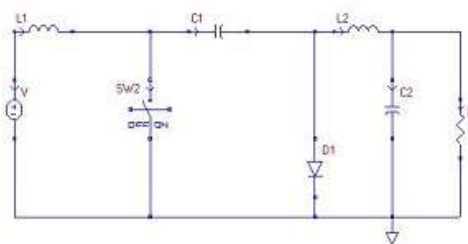

Fig 1. :Cuk converter

In the following sections, the design requirements for this converter will be defined, followed by a derivation of a feedback model for the converter. The final section will describe two different modeling designs for the closed-loop Cuk converter, with the advantages and disadvantages discussed for each. The Canonical Cell forms the basis of analyzing switching circuits, but the energy transport mechanism forms the foundation of the building blocks of such converters. The Buck converter may consequently be seen as a Voltage to Current converter, the Boost as a Current to Voltage converter, the Buck-Boost as a Voltage-Current-Voltage and the CUK as a Current-Voltage-Current converter. All other switching converter MUST fall into one of these configurations if it does not increase the switching stages further for example into a V-I-V-I converter which is difficult to realize through a single controlled switch[2]. It does not require an explanation that a current source must be made to deliver its energy into a voltage sink and vice-versa. A voltage source cannot discharge into a voltage sink and neither can a current source discharge into a current sink. The first would cause current stresses while the latter results in voltage surges. This rule is analogous to the energy exchange between a source of Potential Energy (Voltage of a Capacitor) and a sink of Kinetic Energy (Current in an Inductor) and vice-versa. Both can however discharge into a dissipative load, without causing any voltage or current amplification. The resonant converters also have to agree to some of these basic rules.

II. ANALYSIS OF CUKCONVERTER

The advantages and disadvantages of three basic non-isolated converters can be summarized as given below.

(i) **Buck converter**:- Features of a buck converter are

- Pulsed input current, requires input filter.
- Continuous output current results in lower output voltage ripple.
- Output voltage is always less than input voltage.

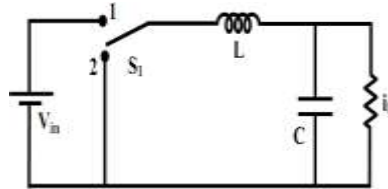

Fig.2: Circuit schematic of a buck converter

(ii) **Boost converter** :- Features of a boost converter are

- Continuous input current, eliminates input filter.
- Pulsed output current increases output voltage ripple.
- Output voltage is always greater than input voltage.

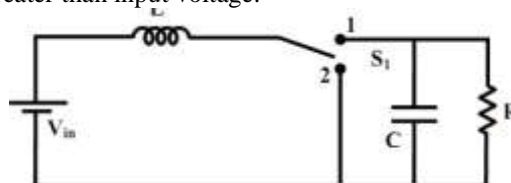

Fig.3: Circuit schematic of a boost converter

(iii) **Buck - Boost converter** :- Features of a buck - boost converter are

- Pulsed input current, requires input filter.
- Pulsed output current increases output voltage ripple
- Output voltage can be either greater or smaller than input voltage.

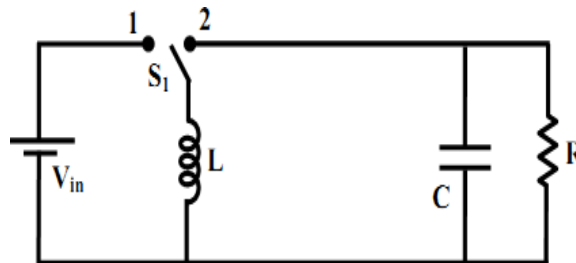

Fig.4: Circuit schematic of a buck boost converter

It will be desirable to combine the advantages of these basic converters into one converter. Cuk converter is one such converter. It has the following advantages.

- Continuous input current.
- Continuous output current.
- Output voltage can be either greater or less than input voltage. Cuk converter is actually the cascade combination of a boost and a buck converter.

III. EXPRESSION FOR AVERAGE OUTPUT VOLTAGE AND INDUCTOR CURRENT

The expression for average output voltage and inductor current are : Applying volt-sec balance across L_1

$$V_{in}DT + (V_{in} - V_{cl})(1-D)T = 0 \quad (1)$$

$$V_{in}(1-D)V_{cl} = 0 \quad (2)$$

Applying Volt-sec balance across L_2

$$(V_o + V_{cl})DT + V_o(1-D)T = 0 \quad (3)$$

$$V_o + DV_{cl} = 0 \quad (4) \quad V_o = -DV_{cl} = -V_{in}D/(1-D) \quad (5)$$

Expression for average inductor current can be obtained from charge balance of C_2

$$I_{L2} + I_o = 0 \quad (6) \quad I_{L2} = I_o = -V_o/R \quad (7)$$

From power balance

$$V_{in}I_{L1} = V_0I_0 = V_0^2/R \quad (8)$$

I_{L1}

$$= \frac{V_0^2}{R} \frac{1}{V_{in}} \quad (9)$$

The Equivalent Circuit of a CUK converter during different conduction modes i.e $0 < t \leq DT$ and $DT < t \leq T$ that are explained by following circuit

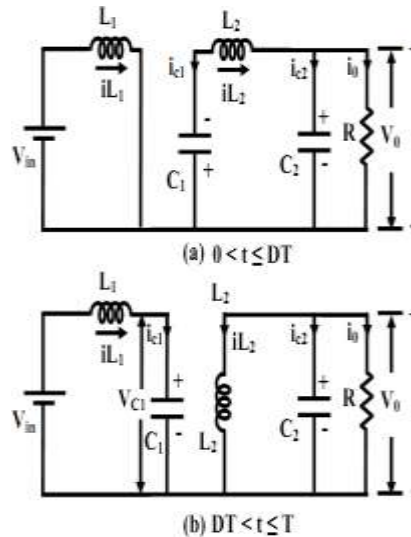

Fig.5: Equivalent Circuit of a CUK converter during different conduction modes. (a) $0 < t \leq DT$ (b) $DT < t \leq T$

IV. HARDWARE IMPLEMENTATION

A. Circuitspecifications

This section covers a simple closed loop controlled Buck/Boost converter with the following specifications

- Input:5V
- Output: INVERTED DCVOLTAGE
- Topology:/CUK Converter using LM2611IC
- Controller:LM2611
- SwitchingFrequency:50kHz
- Protection:None

B. Starting powersupply

- The starting power supply is obtained from a 18V transformer connected to a rectifiercircuit.
- The rectifier circuit consists of 1000microfarad capacitors, 7805 voltage regulators for obtaining positive voltage. Consists of 10nf capacitors and also jumpers to connect to thecircuit.



Fig 6. Starting power supply

C. Hardwarecircuit

It is an electronic circuit which converts a source of direct current (DC) from one voltage level to another.

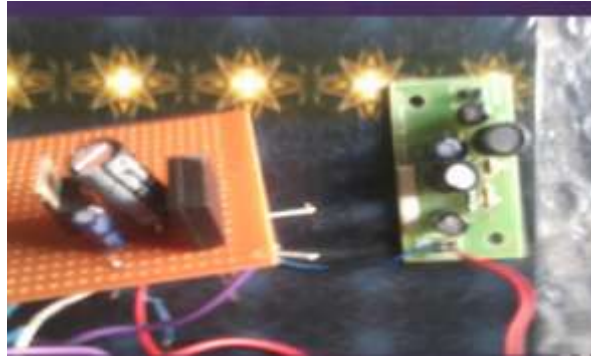

Fig 7: Hardware circuit

V. SIMULATION RESULTS

The simulation example consists of a simple Cuk PWM dc-dc converter as shown in Figure. The input voltage is kept at 25V. The Load resistance is kept at 50. The output filter capacitor is chosen as 100mF. The capacitor C_1 is chosen as 100mF. The switch is controlled by a signal "gce clock", kept at 25kHz frequency and with duty cycle 80%. The output can be controlled by changing the duty cycle parameter for the clock. The switch and diode are ideal switch and diode, respectively.

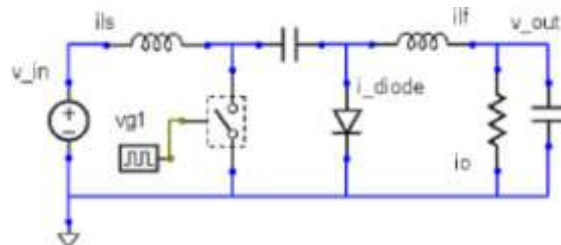

Fig 8. The Schematic circuit for the cuk converter

A. SamplePlots

The sample simulation plots are shown in Fig. Here, the rest upper plot shows the gate driver pulse. The second plot shows the input and output voltages. The third plot shows the switch current, diode current and the source current. All the plots are steady and plotted for one cycle with reference to the time scale.

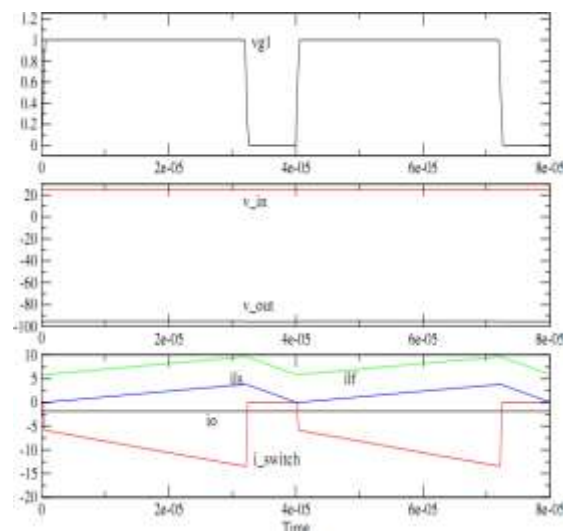

Fig 9: Simulation Plots for Cuk Converter

B. Operation of CUKconverter

The operation of CUK converter can be defined by switch on equivalent and switch off equivalent circuit with is explain by the following diagram which is given below-

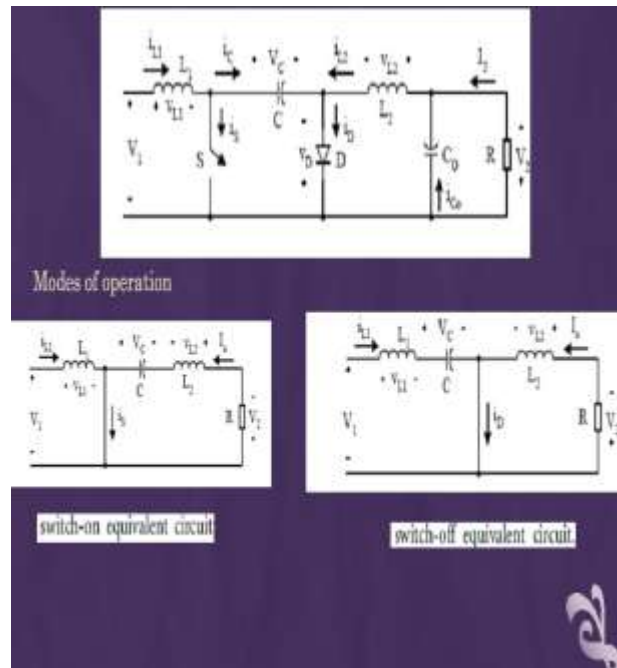

Fig 10. Modes of operation in CUK converter

C. Simulation of practical circuit

PSIM is the leading simulation and design software for power electronics, motor drives, and dynamic system simulation. With fast simulation and easy to use interface, PSIM provides a powerful and efficient environment to meet your simulation needs:

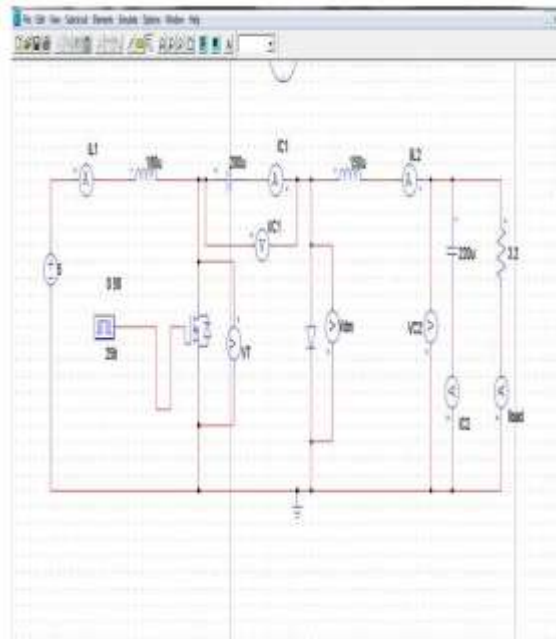

Fig 11. PSIM

VI. CONCLUSION

The CUK converter behaves as an automatic current wave shaper with no current control. Switching frequency harmonics can be reduced by coupling the two inductors as explained. Non idealities inherent to PFR We obtained an inverted voltage /1.64V with an input supply of 5V thus working as a CUK converter. topologies are the lag effect in the input current at zero crossing and the switching harmonics. The switching harmonics are reduced by coupling the inductors. Another Cuk converter following this PFR stage can be designed for zero output ripple thus eliminating ripple from the input as well as the output. Further isolation can be given by introducing high-frequency transformer isolation. The transformer and the two inductors can be integrated into one magnetic structure and both the output

and the input ripple can be transferred to the transformer where the AC ripple inherently exists as the magnetizing current of the transformer

VII. SCOPE FOR FUTUREWORK

Development of multi-stage cuk converter for photo voltaic regulation, Analysis and design of multi-stage, multi/leave, DC/DC converter with input/output bypass capacitor and Simulation and Hardware implementation of Incremental Conductance. MPPT (Maximum Power Point Tracking) with Direct Control method using CUK converter. Power Factor Improvement Using DCM (Discontinuous Conduction mode) CUK converter with Coupled Inductor. Photovoltaic Power converter for military and space applications. Dynamic Maximum power point tracking of Photo voltaic arrays using ripple correlation control

REFERENCES

- [1] Aeronautics and Space Administration, (NASA-CR-149364) National Solar Cell Array Design Handbook, Vol.1, Jet Propulsion Lab, 1976.
- [2] K. Nishioka, N. Sakitani, Y. Uraoka, and T. Fuyuki, "Analysis of multi-crystalline silicon solar cells by modified 3-diode equivalent circuit model taking leakage current through periphery into consideration," *Solar Energy Materials and Solar Cells*, Vol. 91, No. 13, 2007, pp.1222–1227.
- [3] M. R. Islam, R. Saidur, N. A. Rahim, and K. H. Solangi, "Usage of solar energy and its status in Malaysia," *Engineering e- Transaction*, Vol. 5, No. 1, 2010, pp.6-10.
- [4] T. Esum and P. L. Chapman, "Comparison of photovoltaic array maximum power point tracking techniques," *IEEE Transactions on Energy Conversion*, Vol. 22, No. 2, June 2007, pp.439–449.
- [5] K. H. Hussein, I. Muta, T. Hoshino, and M. Osakada, "Maximum photovoltaic power tracking: An algorithm for rapidly changing atmospheric conditions," *Proc. Inst. Elect. Eng., Generation, Transmission and Distribution*, Vol. 142, No. 1, January 1995, pp.59–64.
- [6] N. Mohan, T. M. Undeland, and W. P. Robbins, *Power Electronics: Converters, Applications and Design*, Third Edition, John Wiley, New York, 2003.
- [7] M. H. Rashid, *Power Electronics, Circuits, Devices and Applications*, Third Edition, Prentice Hall, Upper Saddle River, NJ, 2004.
- [8] F. Caricchi, F. Crescimbeni, and A. Di Napoli, "20kW water-cooled prototype of a buck-boost bidirectional DC-DC converter topology for electrical vehicle motor drives," *IEEE APEC Rec.*, pp. 887-892, 1995.
- [9] J. Majo, L. Martinez, A. Poveda, L. Vicuna, F. Guinjoan, A. Sanchez, M. Valentin, and J. Marpinard, "Large-signal feedback control of a bidirectional coupled-inductor cuk converter," *IEEE Trans. Industrial Electronics*, Vol. 39, No. 5, pp. 429-436, Oct. 1992.
- [10] G. Spiazzi and L. Rossetto, "High-quality rectifier based on coupled- inductor sepic topology," *IEEE PESC Rec.*, pp. 336-341, 1998.
- [11] J. J. Jozwick and M. K. Kazimierczuk, "Dual sepic PWM switching- mode DC/DC power converter," *IEEE Trans. on Industrial Electronics*, Vol. 36, No. 1, pp.64-70, Feb.1989.
- [12] D. S. L. Simonetti, J. Sebastian, and J. Uceda, "The discontinuous conduction mode sepic and cuk power factor preregulators: Analysis and design," *IEEE Trans. Industrial Electronics*, Vol. 44, No. 5, pp. 630-637, Oct.1997.
- [13] H. S. Chung, K. K. Tse, S. Y. Hui, C.M. Mok, and M. T. Ho, "A novel maximum power point tracking technique for solar panels using a SEPIC or cuk converter," *IEEE Trans. Power Electronics*, Vol. 18, No. 3, pp. 717-724, May2003.
- [14] Maged N. F. Nashed, "Design of a digital PWM controller for a soft switching sepic converter," *Journal of Power Electronics*, Vol. 4, No. 3, pp. 152-160, Jul.2004.